

Wafer Butterfly Valve (DBV1603WL), PN16 (DBV1603WG), PN16

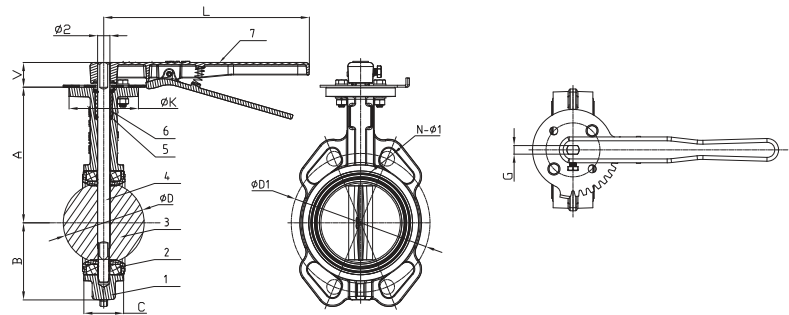

(DBV1603WL), PN16

Rubber Seat with Backing
Cartridge Style



MATERIAL SPECIFICATION

Part No.	Part	Standard Specification	Options
1	Valve Body	EN-GJS-450-10	
2	Seat	DN40~400: EPDM & Backing DN450~800: EPDM Vulcanized on Valve Body	NBR/Fluororubber&Backing EPDM/NBR Vulcanized on Valve Body Soft Seat in EPDM/NBR
3	Disc	EN-GJS-450-10	SS304, SS316, AL-Bronze C95400
4	Stem	DN40~350: Stainless Steel, One-Piece Stem Design DN400~800: Stainless Steel, Two-Piece Stem Design	SS304, SS316, SS420, SS431
5	O-Ring	NBR	EPDM
6	Bushing	DN40~350: Nylon 1010 DN400~800: Lubricating Bronze	PTFE
7	Lever	EN-GJS-450-10	Aluminum
8	Shaft Cover (DN400~800)	EN-GJS-450-10	
9	Gear Box	EN-GJS-450-10	

Note: For special material request other than standard specification, please indicate clearly on the inquiry or order list.

- Design Standard: BS EN 593
- Connection Ends: Universal Flange to BS EN 1092 PN10/PN16,
- Top Flange Standard: ISO 5211
Stem drive by keys, parallel or diagonal square or flat head
- Working Pressure PN16
- Temperature Range: 0°C- 100°C
- Coating: Fusion Bonded Epoxy Coating in accordance with ANSI/AWWA C550

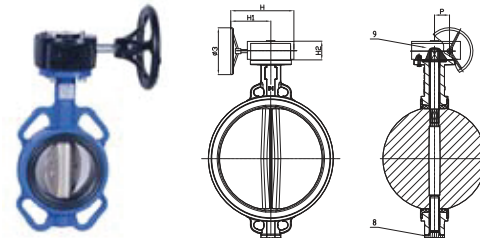

(DBV1603WG), PN16

Rubber Seat with Backing
Cartridge Style

DN		Dimensions (mm)																		
Inch	mm	A	B	V	C	ØD	Ø2	ØK	G	L	ØD1	N-Ø1	ISO 5211	Ø3	H	H1	H2	P		
													PN16							
1.5"	40	138	64.5	32	33	43.9	14	90	9.45	267	110	4-Ø19	F07	150	206	158	52	43.5		
2"	50	140.5	64.5	32	43	53.9	14	90	9.53	267	125	4-Ø19	F07	150	206	158	52	43.5		
2.5"	65	153	72	32	46	65.2	14	90	9.53	267	145	4-Ø19	F07	150	206	158	52	43.5		
3"	80	157.5	86	32	46	79.7	14	90	9.53	267	160	8-Ø19	F07	150	206	158	52	43.5		
4"	100	176	100	32	52	105	16	90	11.14	267	180	8-Ø19	F07	150	206	158	52	43.5		
5"	125	191	112	32	56	130	16	90	11.14	267	210	8-Ø19	F07	150	206	158	52	43.5		
6"	150	202.5	128	32	56	156	20	90	12.7	267	240	8-Ø23	F07	150	206	158	52	43.5		
8"	200	243.5	162	45	60	206.7	26	125	20.6	356	295	12-Ø23	F10	300	310	239	69	62.5		
10"	250	273	194	45	68	253.3	26	125	20.6	490	355	12-Ø28	F10	300	310	239	69	62.5		
12"	300	311	223	45	78	301.9	28	125	22.1	490	410	12-Ø28	F10	300	307	229	73	77.5		
14"	350	340	267	48	78	333.9	31.6	150	22.1	-	470	16-Ø28	F12	300	307	229	73	77.5		
16"	400	400	319.5	48	102	389.6	33.2	175	27	-	525	16-Ø31	F14	380	418	288	110	120		
18"	450	422	345.4	48	114	441	38.1	175	27	-	585	20-Ø31	F14	380	418	288	110	120		
20"	500	480	380	70.2	127	492.4	41.2	210	-	-	650	20-Ø34	F16	380	465	215	123	185		
24"	600	562	441	70.2	154	592.8	50.6	210	-	-	770	20-Ø37	F16	380	500	215	129	185		
													PN10							
28"	700	575	505	70.2	165	695	63.4	300	-	-	840	24-Ø31	F25	380	543	213	132	218		
30"	750	660	550	70.2	165	744	63.4	300	-	-	900	24-Ø34	F25	380	543	213	132	218		
32"	800	667	577	70.2	190	795.7	63.4	300	-	-	950	24-Ø34	F25	380	543	213	132	218		

Note: Not designed for dead end service