

## Flanged Y-Type Strainer (DYS1605), PN16 (DYS2505), PN25

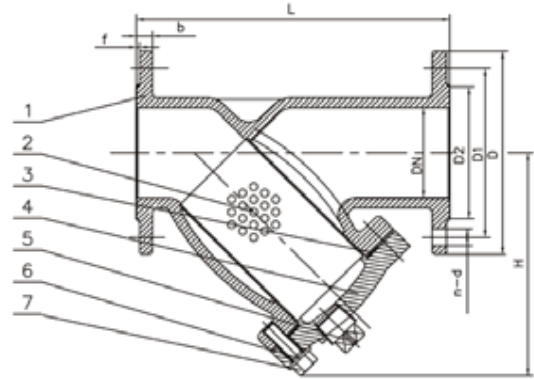

### MATERIAL SPECIFICATION

Part No.	Part	Standard Specification	Options
1	Valve Body	EN-GJS-450-10	
2	Screen	SS304 (Perforated)	SS304, SS316 (Perforated, Knitted, Double Screen)
3	Gasket	Graphite+Acanthopore Plate	EPDM
4	Bonnet	EN-GJS-450-10	
5	Plug	Malleable Iron Galvanized	Bronze ASTM B584
6	Bolt	Carbon Steel Zinc Plated	SS304, SS316
7	Flat Washer	Carbon Steel Zinc Plated	SS304, SS316

Note: For special material request other than standard specification, please indicate clearly on the inquiry or order list.

- Connection Ends: Flange to BS EN 1092-2:1997  
Working Pressure PN16 / PN25
- Temperature Range: -10°C- 200°C graphite gasket  
0°C- 100°C rubber gasket
- Coating: Fusion Bonded Epoxy Coating in accordance with  
ANSI/AWWA C550

DN		PN	Dimensions(mm)								
Inch	mm		L	D	D1	D2	b	n-Φd	f	H	
1/2"	15	10/16/25	130±2	95	65	45	14	4-Φ14	2	59	
3/4"	20	10/16/25	150±2	105	75	56	16	4-Φ14	2	68	
1"	25	10/16/25	160±2	115	85	65	16	4-Φ14	3	70	
1 1/4"	32	10/16/25	180±2	140	100	76	18	4-Φ19	3	86	
1.5"	40	10/16/25	200	150	110	90	19	4-Φ19	3	140	
2"	50	10/16/25	230	165	125	99	19	4-Φ19	3	140	
2.5"	65	10/16	290	185	145	118	19	4-Φ19	3	175	
		25						8-Φ19			
3"	80	10/16/25	310	200	160	132	19	8-Φ19	3	198	
		10/16						8-Φ19			
4"	100	25	350	220	180	156	19	8-Φ19	3	229	
		10/16						8-Φ23			
5"	125	10/16	400	250	210	184	19	8-Φ19	3	287	
		10/16						8-Φ23			
6"	150	25	480	285	240	211	19	8-Φ23	3	304	
		10/16						8-Φ28			
8"	200	10	600	340	295	266	20	8-Φ23	3	370.5	
		16						12-Φ23			
		25						12-Φ28			
10"	250	10	730	405	350	319	22	12-Φ23	3	469	
		16						12-Φ28			
		25						12-Φ31			
		10/16						12-Φ31			
12"	300	10	850	460	400	370	24.5	12-Φ23	4	540	
		16						12-Φ28			
		25						16-Φ31			
14"	350	10	838	520	460	429	26.5	16-Φ23	4	625	
		16						16-Φ28			
		10/16						16-Φ31			
16"	400	10	864	580	515	480	28	16-Φ28	4	715	
		16						16-Φ31			
		10/16						16-Φ31			
18"	450	10	1200	640	565	530	30	20-Φ28	4	862	
		16						20-Φ31			
		10/16						20-Φ31			
20"	500	10	1250	715	620	582	31.5	20-Φ28	4	926	
		16						20-Φ34			
		10/16						20-Φ34			
24"	600	10	1450	840	725	682	36	20-Φ31	5	1057	
		16						20-Φ37			
		10/16						20-Φ37			

### SHORT STYLE

DN		PN	Dimensions(mm)								
Inch	mm		L	D	D1	D2	b	n-Φd	f	H	
18"	450	10	850	640	565	530	30	20-Φ28	4	693	
		16			585	548		20-Φ31			
20"	500	10	1000	715	620	582	31.5	20-Φ28	4	774	
		16			650	609		20-Φ34			
		10/16			725	682		20-Φ31			
24"	600	10	1100	840	770	720	36	20-Φ37	5	956	
		16			770	720		20-Φ37			